

SUBMITTAL DATA SHEET	CH-M12DTUI	CH-12SHP-230VO
-----------------------------	-------------------	-----------------------

Job Name:
 Location:
 Engineer:
 Submitted to:
 Submitted by:
 Reference:

Date:
 Approval:
 Construction:
 Unit #:
 Drawing #:



PERFORMANCE AND EFFICIENCY

Cooling		Heating	
12,000 Btu/h		12,000 Btu/h	
SEER	21.5	HSPF	11.5
EER	12.5		

OPERATION TEMPERATURE RANGE

Indoor		Outdoor	
cooling	heating	cooling	heating
62~90°F	32~86°F	-13~122°F	-13~86°F

ELECTRICAL

Power supply	208-230V/ 60Hz, 1Ph
MCA	12 A
MFA	15 A

MCA: Minimum Circuit Ampacity

MFA: Max. fuse A

PIPING

Refrigerant piping Liquid side/Gas side	1/4 - 1/2 in
Max. refrigerant pipe length	82 ft
Max. difference in level	33 ft



This warranty should be registered on our web-site www.cooperandhunter.us within 60 days of installation. The warranty is only valid when installed by a Licensed HVAC Technician. A warranty period of Seven (7) years on compressor to the original registered end-user. A warranty period of Five (5) years on all parts to the original registered end user. Warranty applies only to products remaining in their original installation location.

INDOOR SPECIFICATION

Air Flow (Hi/Mi/Lo)	353/283/177 CFM
Noise Level (Hi/Mi/Lo)	38/36/33.5 dB(A)
Unit Dimension (WxDxH)	27.56x19.92x7.87 in
Net/Gross weight	37.5/48.3 lb

OUTDOOR SPECIFICATION

Air flow	1177 CFM
Noise Level	55 dB(A)
Dimension (WxDxH)	31.50x13.11x21.81 in
Net/Gross weight	76.72/82.67 lb
Refrigerant type/Quantity	R410A/40.6 oz
Refrigerant precharge	25 ft
Additional charge for each ft	0.16 oz

SUBMITTAL DATA SHEET	CH-M12DTUI	CH-12SHP-230VO
----------------------	------------	----------------

INDOOR UNIT

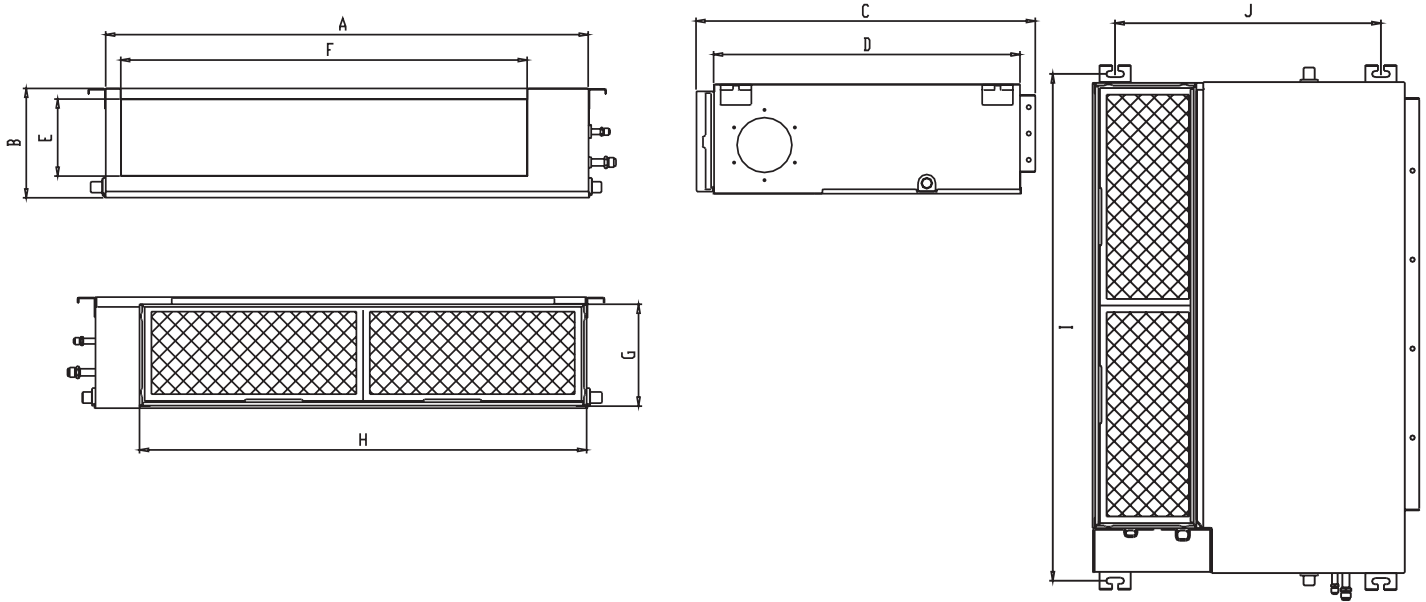

Outline dimension				air outlet opening size		air return opening size		Size of mounted lug	
A	B	C	D	E	F	G	H	I	J
27.56	7.87	19.92	17.72	6	21.1	7.3	23.6	29.2	14.2

OUTDOOR UNIT

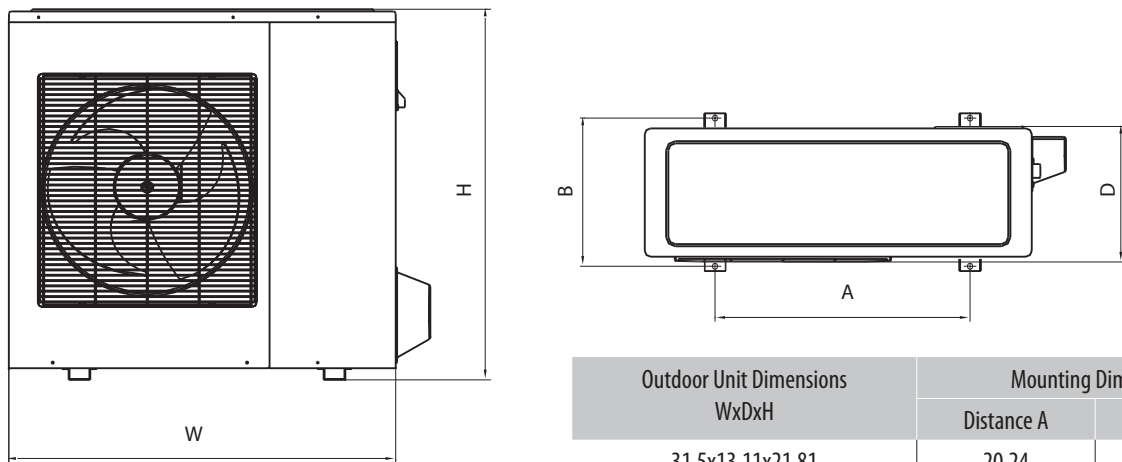

Outdoor Unit Dimensions WxDxH	Mounting Dimensions	
	Distance A	Distance B
31.5x13.11x21.81	20.24	13.39