

SUBMITTAL DATA SHEET	CH-NG09MIA115VI	CH-NG09MIA115VO
----------------------	-----------------	-----------------

Job Name: .....  
 Location: .....  
 Engineer: .....  
 Submitted to: .....  
 Submitted by: .....  
 Reference: .....

Date: .....  
 Approval: .....  
 Construction: .....  
 Unit #: .....  
 Drawing #: .....



### PERFORMANCE AND EFFICIENCY

Cooling		Heating	
9,000 Btu/h		10,000 Btu/h	
SEER	19	HSPF4/ HSPF5	10/7.8
EER	11.5	COP	3.11

### OPERATION TEMPERATURE RANGE

Indoor		Outdoor	
cooling	heating	cooling	heating
62~90°F	32~86°F	5~122°F	5~86°F

### ELECTRICAL

Power supply	208-230V/ 60Hz, 1Ph
MCA	15 A
MFA	20 A

**MCA:** Minimum Circuit Ampacity

**MFA:** Max. fuse A

### PIPING

Refrigerant piping Liquid side/Gas side	1/4 - 3/8 in
Max. refrigerant pipe length	82 ft
Max. difference in level	33 ft



This warranty should be registered on our web-site [www.cooperandhunter.us](http://www.cooperandhunter.us) within 60 days of installation. The warranty is only valid when installed by a Licensed HVAC Technician. A warranty period of Seven (7) years on compressor to the original registered end-user. A warranty period of Five (5) years on all parts to the original registered end user. Warranty applies only to products remaining in their original installation location.

### INDOOR SPECIFICATION

Air Flow (Hi/Mi/Lo)	247/182/129 CFM
Noise Level (Hi/Mi/Lo)	38/32/25 dB(A)
Unit Dimension (WxDxH)	28.43x7.36x11.42 in
Net/Gross Weight	17.2/22.7 lb

### OUTDOOR SPECIFICATION

Air flow	1176 CFM
Noise Level	52 dB(A)
Dimension (WxDxH)	30.31x11.81x21.85 in
Net/Gross weight	66.8/71.87 lb
Refrigerant type/Quantity	R410A/30 oz
Refrigerant precharge	25 ft
Additional charge for each ft	0.16 oz

SUBMITTAL DATA SHEET

CH-NG09MIA115VI

CH-NG09MIA115VO

### INDOOR UNIT

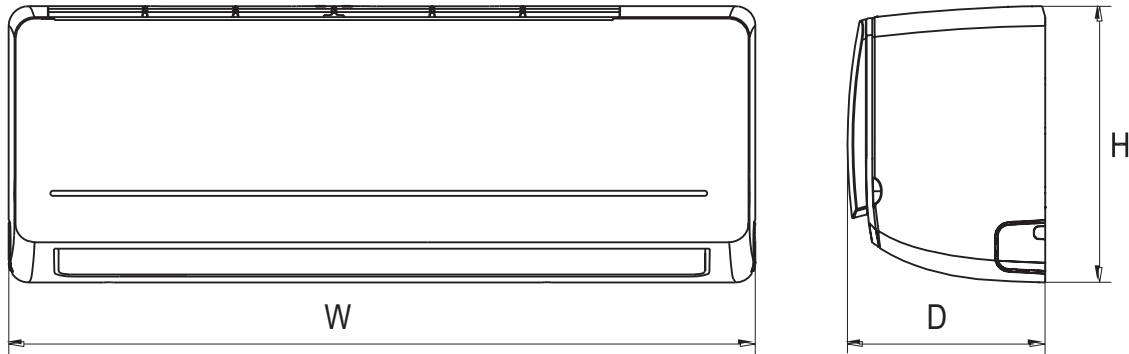

Indoor Unit Dimensions in		
W	D	H
28.43	7.36	11.42

### OUTDOOR UNIT

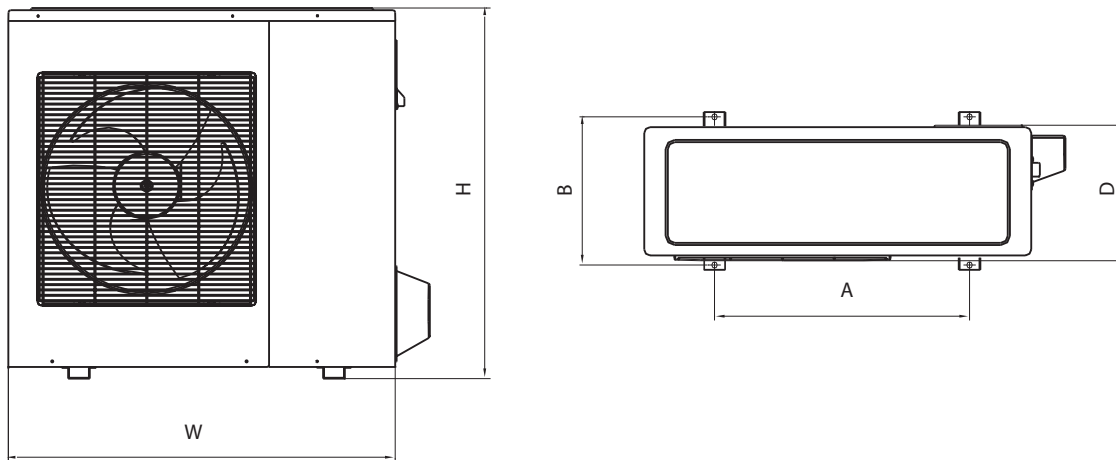

Outdoor Unit Dimensions WxDxH	Mounting Dimensions	
	Distance A	Distance B
30.31x11.81x21.85	19.17	11.69