

SUBMITTAL DATA SHEET	CH-NG12MIA230VI	CH-NG12MIA230VO
----------------------	-----------------	-----------------

Job Name:
 Location:
 Engineer:
 Submitted to:
 Submitted by:
 Reference:

Date:
 Approval:
 Construction:
 Unit #:
 Drawing #:



PERFORMANCE AND EFFICIENCY

Cooling		Heating	
12,000 Btu/h		12,000 Btu/h	
SEER	19	HSPF4/ HSPF5	9.5/8
EER	11	COP	3.43

OPERATION TEMPERATURE RANGE

Indoor		Outdoor	
cooling	heating	cooling	heating
62~90°F	32~86°F	5~122°F	5~86°F

ELECTRICAL

Power supply	208-230V/ 60Hz, 1Ph
MCA	15 A
MFA	15 A

MCA: Minimum Circuit Ampacity

MFA: Max. fuse A

PIPING

Refrigerant piping Liquid side/Gas side	1/4 - 1/2 in
Max. refrigerant pipe length	82 ft
Max. difference in level	33 ft



This warranty should be registered on our web-site www.cooperandhunter.us within 60 days of installation. The warranty is only valid when installed by a Licensed HVAC Technician. A warranty period of Seven (7) years on compressor to the original registered end-user. A warranty period of Five (5) years on all parts to the original registered end user. Warranty applies only to products remaining in their original installation location.

INDOOR SPECIFICATION

Air Flow (Hi/Mi/Lo)	324/282/212 CFM
Noise Level (Hi/Mi/Lo)	38/32/24 dB(A)
Unit Dimension (WxDxH)	31.57x7.44x11.69 in
Net/Gross Weight	18.96/24.91 lb

OUTDOOR SPECIFICATION

Air flow	1176 CFM
Noise Level	55 dB(A)
Dimension (WxDxH)	31.5x13.1x21.8 in
Net/Gross weight	67.0/72.75 lb
Refrigerant type/Quantity	R410A/29.63 oz
Refrigerant precharge	25 ft
Additional charge for each ft	0.16 oz

SUBMITTAL DATA SHEET

CH-NG12MIA230VI

CH-NG12MIA230VO

INDOOR UNIT

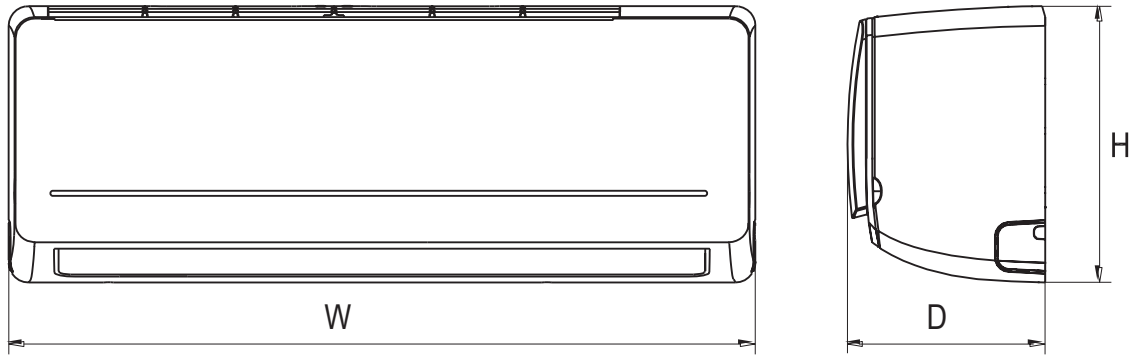

Indoor Unit Dimensions in		
W	D	H
37.99	8.46	12.56

OUTDOOR UNIT

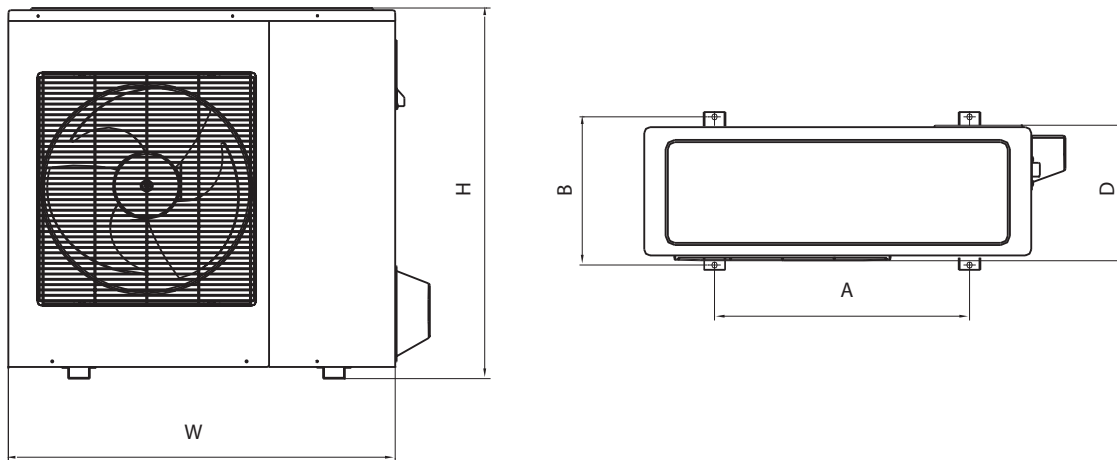

Outdoor Unit Dimensions WxDxH	Mounting Dimensions	
	Distance A	Distance B
31.5x13.11x21.81	20.24	13.39