

SUBMITTAL DATA SHEET	CH-48LCFCI	CH-48LCUO
-----------------------------	-------------------	------------------

Job Name:
 Location:
 Engineer:
 Submitted to:
 Submitted by:
 Reference:

Date:
 Approval:
 Construction:
 Unit #:
 Drawing #:



This warranty should be registered on our web-site www.cooperandhunter.us within 60 days of installation. The warranty is only valid when installed by a Licensed HVAC Technician. A warranty period of Seven (7) years on compressor to the original registered end-user. A warranty period of Five (5) years on all parts to the original registered end user. Warranty applies only to products remaining in their original installation location.

INDOOR SPECIFICATION

Air Flow (Hi/Mi/Lo)	1350/1120/1000 CFM
Noise Level (Hi/Mi/Lo)	57/54/52 dB(A)
Unit Dimension (WxDxH)	64.96x26.57x9.25 in
Net/Gross Weight	83.78/97 lb

OUTDOOR SPECIFICATION

Air flow	4470 CFM
Noise Level	62.5 dB(A)
Dimension (WxDxH)	37.48x16.34x52.48 in
Net/Gross weight	217.4/246.0 lb
Refrigerant type/Quantity	R410A/148.2 oz
Refrigerant precharge	25 ft
Additional charge for each ft	0.32 oz

PERFORMANCE AND EFFICIENCY

Cooling		Heating	
48,000 Btu/h		50,000 Btu/h	
SEER	17.8	HSPF	11
EER	9.3	Region IV	

Heating/ Cooling	Outdoor Dry Bulb	Indoor Dry Bulb	Unit	Min	Rated	Max
Heating	5°F	70°F	Btu/h	3,466	-	36,290
			kW	1.01	-	5.56
			COP	1.01	-	1.91
	17°F	70°F	Btu/h	6,680	35,000	40,834
			kW	1.04	4.35	5.13
			COP	1.88	2.36	2.33
47°F	70°F	Btu/h	11,294	50,000	57,072	
		kW	0.69	4.58	5.49	
		COP	4.8	3.2	3.05	
Cooling	82°F	80°F	Btu/h	16,610	-	52,433
			kW	0.71	-	4.58
			COP	6.86	-	3.36
	95°F	80°F	Btu/h	12,423	48,000	48,100
			kW	0.79	5.16	5.22
			COP	4.61	2.73	2.7

OPERATION TEMPERATURE RANGE

Indoor		Outdoor	
cooling	heating	cooling	heating
62~90°F	32~86°F	5~122°F	5~86°F

ELECTRICAL

	Power supply	208-230V/ 60Hz, 1Ph
	MCA	35
	MFA	50
Outdoor fan motor	Input	126 W
	RLA	0.39 A
Compressor	Capacity	44,697 Btu/h
	Input	3,420
	RLA	23.5

MCA: Minimum Circuit Ampacity **MFA:** Max. fuse A **RLA:** Rated Load

PIPING

Refrigerant piping Liquid side/Gas side	3/8 - 5/8 in
Max. refrigerant pipe length	213 ft
Max. difference in level	98 ft

SUBMITTAL DATA SHEET	CH-48LCFCI	CH-48LCUO
----------------------	------------	-----------

INDOOR UNIT

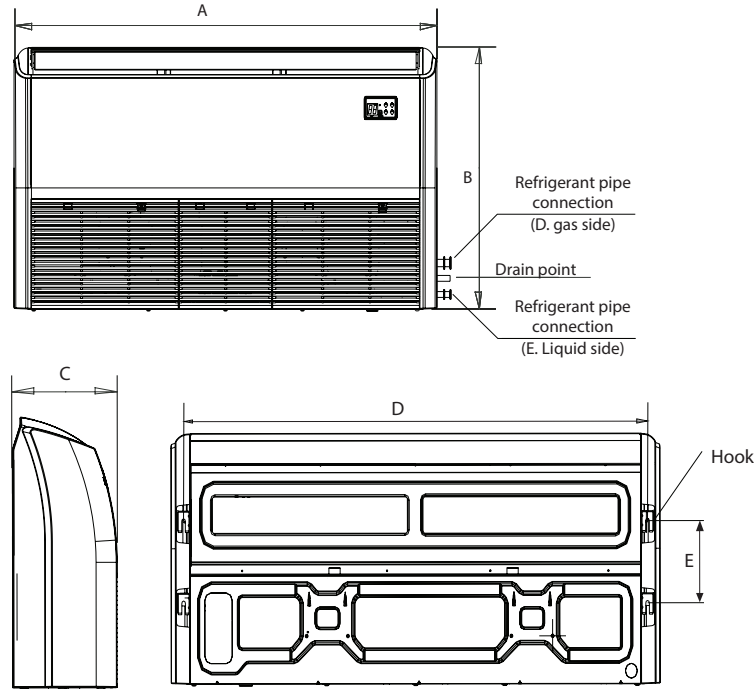

Unit Dimensions, in			Mounting Dimensions, in	
A	B	C	D	E
64.96	26.57	9.25	61.6	8.7

OUTDOOR UNIT

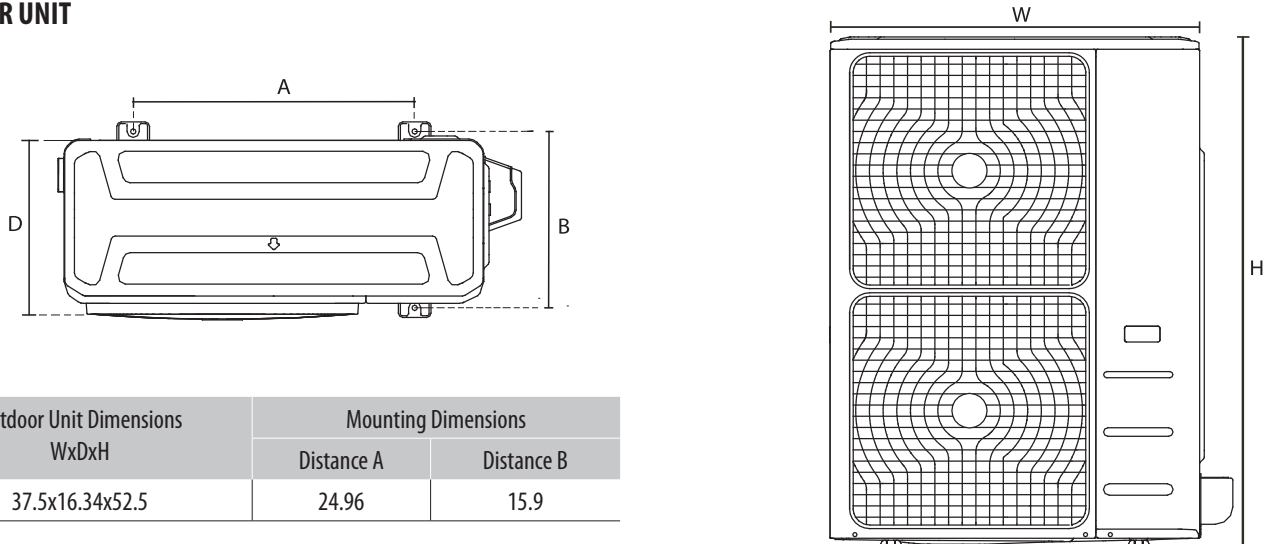

Outdoor Unit Dimensions WxDxH	Mounting Dimensions	
	Distance A	Distance B
37.5x16.34x52.5	24.96	15.9